

120V - 100W DMOS AUDIO AMPLIFIER WITH MUTE/ST-BY

- VERY HIGH OPERATING VOLTAGE RANGE ($\pm 50V$)
- DMOS POWER STAGE
- HIGH OUTPUT POWER (100W @ THD = 10%, $R_L = 8\Omega$, $V_s = \pm 40V$)
- MUTING/STAND-BY FUNCTIONS
- NO SWITCH ON/OFF NOISE
- VERY LOW DISTORTION
- VERY LOW NOISE
- SHORT CIRCUIT PROTECTED (WITH NO INPUT SIGNAL APPLIED)
- THERMAL SHUTDOWN
- CLIP DETECTOR
- MODULARITY (MORE DEVICES CAN BE EASILY CONNECTED IN PARALLEL TO DRIVE VERY LOW IMPEDANCES)

MULTIPOWER BCD TECHNOLOGY

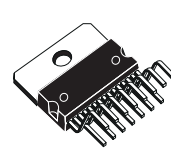

Multiwatt15V

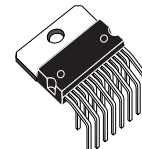

Multiwatt15H

ORDERING NUMBERS:

TDA7293V

TDA7293HS

class TV). Thanks to the wide voltage range and to the high out current capability it is able to supply the highest power into both 4 Ω and 8 Ω loads.

The built in muting function with turn on delay simplifies the remote operation avoiding switching on-off noises.

Parallel mode is made possible by connecting more device through of pin11. High output power can be delivered to very low impedance loads, so optimizing the thermal dissipation of the system.

DESCRIPTION

The TDA7293 is a monolithic integrated circuit in Multiwatt15 package, intended for use as audio class AB amplifier in Hi-Fi field applications (Home Stereo, self powered loudspeakers, Top-

Figure 1: Typical Application and Test Circuit

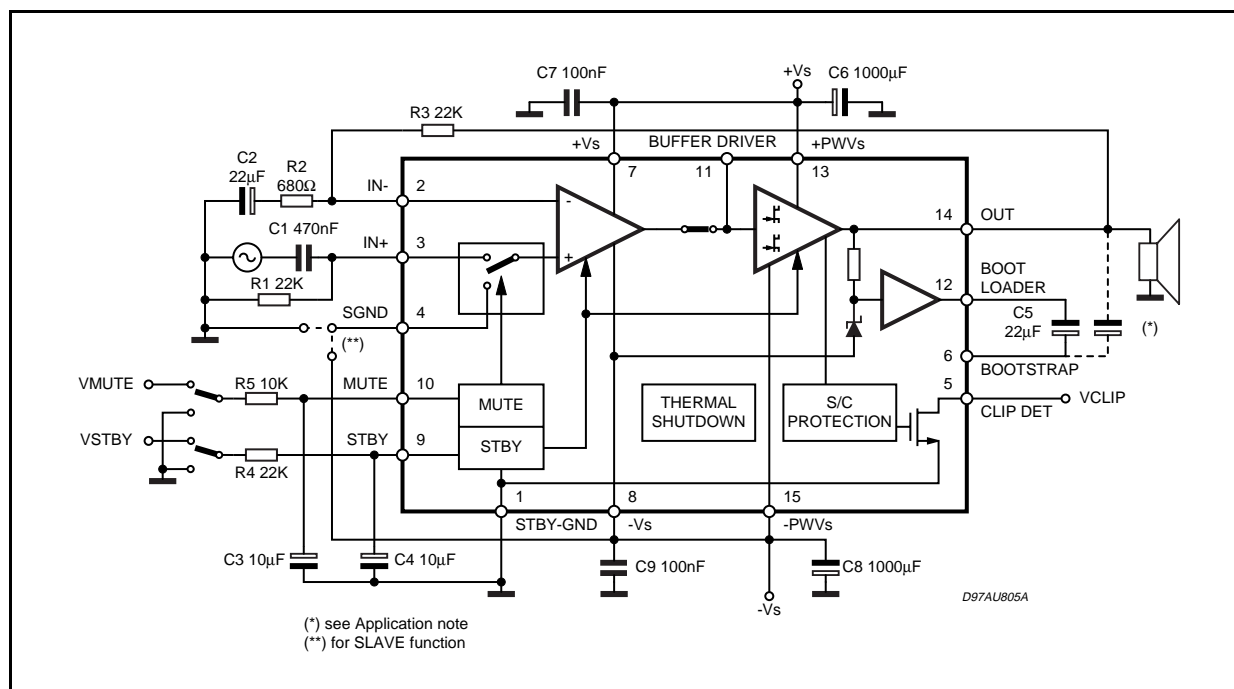

(*) see Application note
(**) for SLAVE function

PIN CONNECTION (Top view)

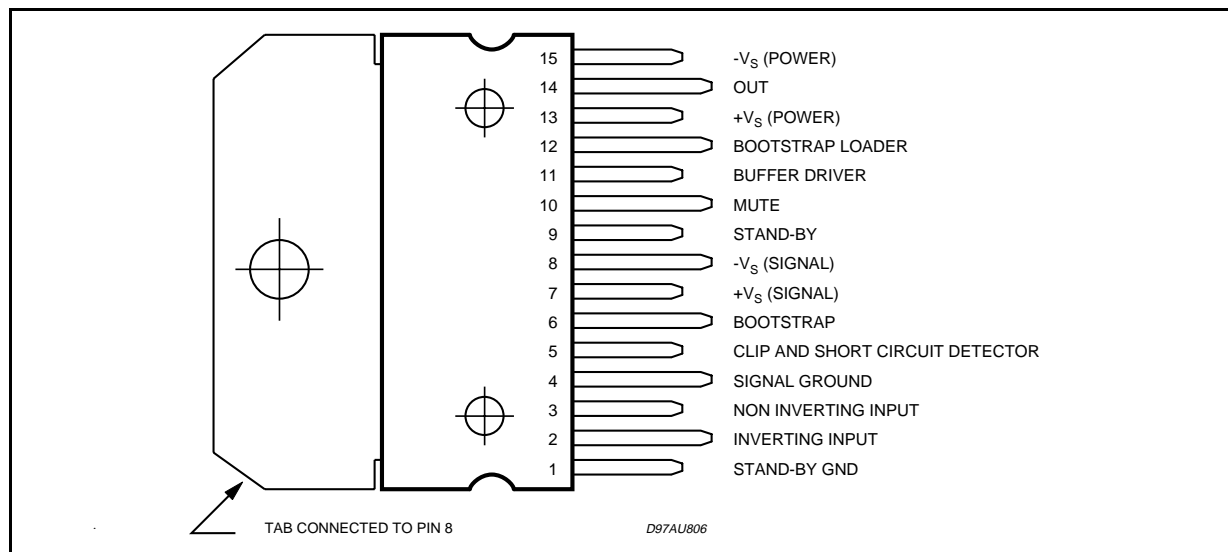

ABSOLUTE MAXIMUM RATINGS

Symbol	Parameter	Value	Unit
V_S	Supply Voltage (No Signal)	± 60	V
V_1	$V_{STAND-BY}$ GND Voltage Referred to $-V_S$ (pin 8)	90	V
V_2	Input Voltage (inverting) Referred to $-V_S$	90	V
$V_2 - V_3$	Maximum Differential Inputs	± 30	V
V_3	Input Voltage (non inverting) Referred to $-V_S$	90	V
V_4	Signal GND Voltage Referred to $-V_S$	90	V
V_5	Clip Detector Voltage Referred to $-V_S$	120	V
V_6	Bootstrap Voltage Referred to $-V_S$	120	V
V_9	Stand-by Voltage Referred to $-V_S$	120	V
V_{10}	Mute Voltage Referred to $-V_S$	120	V
V_{11}	Buffer Voltage Referred to $-V_S$	120	V
V_{12}	Bootstrap Loader Voltage Referred to $-V_S$	100	V
I_O	Output Peak Current	10	A
P_{tot}	Power Dissipation $T_{case} = 70^\circ C$	50	W
T_{op}	Operating Ambient Temperature Range	0 to 70	$^\circ C$
T_{stg}, T_j	Storage and Junction Temperature	150	$^\circ C$

THERMAL DATA

Symbol	Description	Typ	Max	Unit
$R_{th\ j-case}$	Thermal Resistance Junction-case	1	1.5	$^\circ C/W$

ELECTRICAL CHARACTERISTICS (Refer to the Test Circuit $V_S = \pm 40V$, $R_L = 8\Omega$, $R_G = 50\Omega$; $T_{amb} = 25^\circ C$, $f = 1\text{ kHz}$; unless otherwise specified).

Symbol	Parameter	Test Condition	Min.	Typ.	Max.	Unit
V_S	Supply Range		± 12		± 50	V
I_q	Quiescent Current			50	100	mA
I_b	Input Bias Current			0.3	1	μA
V_{OS}	Input Offset Voltage		-10		10	mV
I_{OS}	Input Offset Current				0.2	μA
P_O	RMS Continuous Output Power	d = 1%: $R_L = 4\Omega$; $V_S = \pm 29V$,	75	80 80		W
		d = 10% $R_L = 4\Omega$; $V_S = \pm 29V$	90	100 100		W
d	Total Harmonic Distortion (**)	$P_O = 5W$; $f = 1\text{ kHz}$ $P_O = 0.1\text{ to }50W$; $f = 20\text{ Hz to }15\text{ kHz}$		0.005	0.1	% %
I_{SC}	Current Limiter Threshold	$V_S \leq \pm 40V$		6.5		A
SR	Slew Rate		5	10		V/ μs
G_V	Open Loop Voltage Gain			80		dB
G_V	Closed Loop Voltage Gain (1)		29	30	31	dB
e_N	Total Input Noise	A = curve $f = 20\text{ Hz to }20\text{ kHz}$		1		μV
				3	10	μV
R_i	Input Resistance		100			k Ω
SVR	Supply Voltage Rejection	$f = 100\text{ Hz}$; $V_{ripple} = 0.5V_{rms}$		75		dB
T_S	Thermal Protection	DEVICE MUTED		150		$^\circ C$
		DEVICE SHUT DOWN		160		$^\circ C$
STAND-BY FUNCTION (Ref: to pin 1)						
$V_{ST\ on}$	Stand-by on Threshold				1.5	V
$V_{ST\ off}$	Stand-by off Threshold		3.5			V
ATT_{st-by}	Stand-by Attenuation		70	90		dB
$I_{q\ st-by}$	Quiescent Current @ Stand-by			0.5	1	mA
MUTE FUNCTION (Ref: to pin 1)						
V_{Mon}	Mute on Threshold				1.5	V
V_{Moff}	Mute off Threshold		3.5			V
ATT_{mute}	Mute Attenuation		60	80		dB
CLIP DETECTOR						
Duty	Duty Cycle (pin 5)	THD = 1% ; $R_L = 10K\Omega\text{ to }5V$		10		%
		THD = 10% ; $R_L = 10K\Omega\text{ to }5V$	30	40	50	%
I_{CLEAK}		$P_O = 50W$			3	μA
SLAVE FUNCTION pin 4 (Ref: to pin 8 -Vs)						
V_{Slave}	SlaveThreshold				1	V
V_{Master}	Master Threshold		3			V

Note (1): $G_{Vmin} \geq 26\text{ dB}$

Note: Pin 11 only for modular connection. Max external load 1M Ω /10 pF, only for test purpose

Note ():** Tested with optimized Application Board (see fig. 2)

TDA7293

Figure 2: Typical Application P.C. Board and Component Layout (scale 1:1)

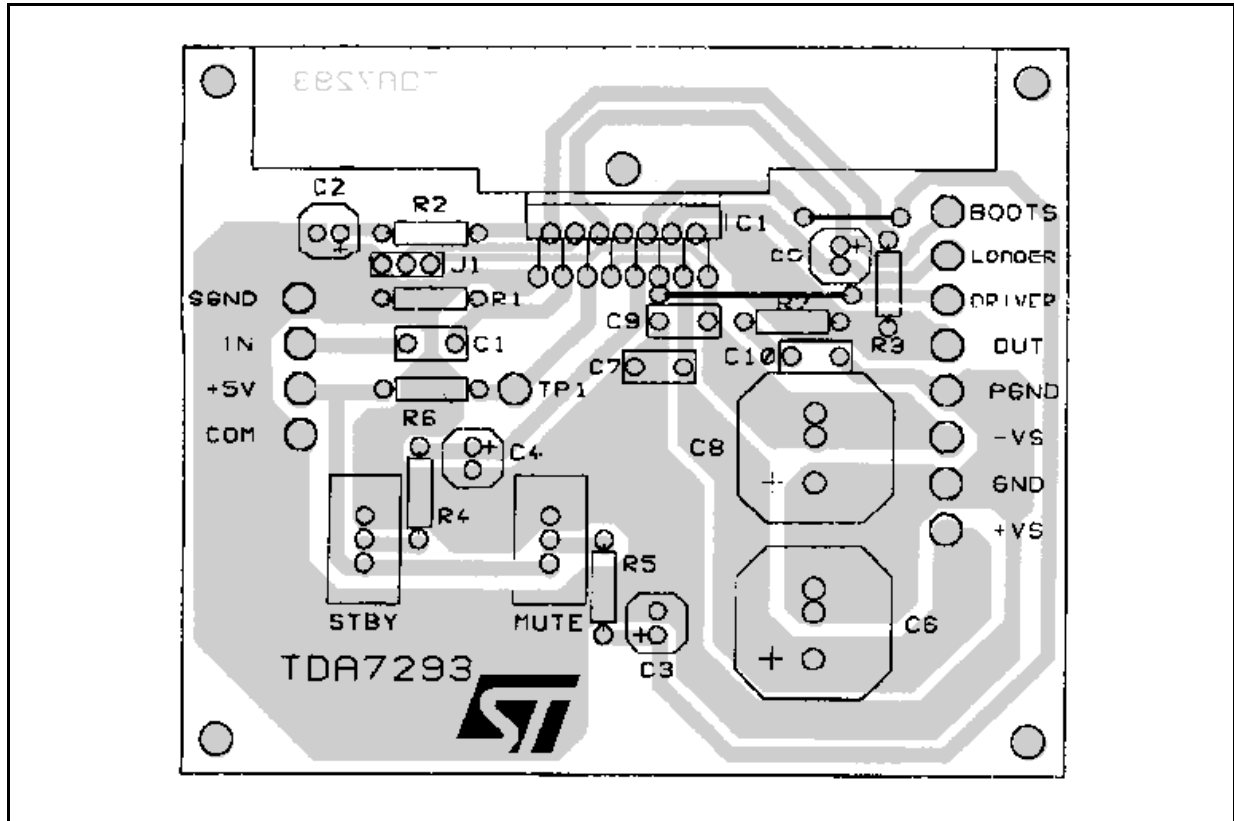

APPLICATION SUGGESTIONS (see Test and Application Circuits of the Fig. 1)

The recommended values of the external components are those shown on the application circuit of Figure 1. Different values can be used; the following table can help the designer.

COMPONENTS	SUGGESTED VALUE	PURPOSE	LARGER THAN SUGGESTED	SMALLER THAN SUGGESTED
R1 (*)	22k	INPUT RESISTANCE	INCREASE INPUT IMPEDANCE	DECREASE INPUT IMPEDANCE
R2	680 Ω	CLOSED LOOP GAIN SET TO 30dB (**)	DECREASE OF GAIN	INCREASE OF GAIN
R3 (*)	22k		INCREASE OF GAIN	DECREASE OF GAIN
R4	22k	ST-BY TIME CONSTANT	LARGER ST-BY ON/OFF TIME	SMALLER ST-BY ON/OFF TIME; POP NOISE
R5	10k	MUTE TIME CONSTANT	LARGER MUTE ON/OFF TIME	SMALLER MUTE ON/OFF TIME
C1	0.47 μ F	INPUT DC DECOUPLING		HIGHER LOW FREQUENCY CUTOFF
C2	22 μ F	FEEDBACK DC DECOUPLING		HIGHER LOW FREQUENCY CUTOFF
C3	10 μ F	MUTE TIME CONSTANT	LARGER MUTE ON/OFF TIME	SMALLER MUTE ON/OFF TIME
C4	10 μ F	ST-BY TIME CONSTANT	LARGER ST-BY ON/OFF TIME	SMALLER ST-BY ON/OFF TIME; POP NOISE
C5	22 μ FXN (***)	BOOTSTRAPPING		SIGNAL DEGRADATION AT LOW FREQUENCY
C6, C8	1000 μ F	SUPPLY VOLTAGE BYPASS		
C7, C9	0.1 μ F	SUPPLY VOLTAGE BYPASS		DANGER OF OSCILLATION

(*) R1 = R3 for pop optimization

(**) Closed Loop Gain has to be ≥ 26 dB

(***) Multiplay this value for the number of modular part connected

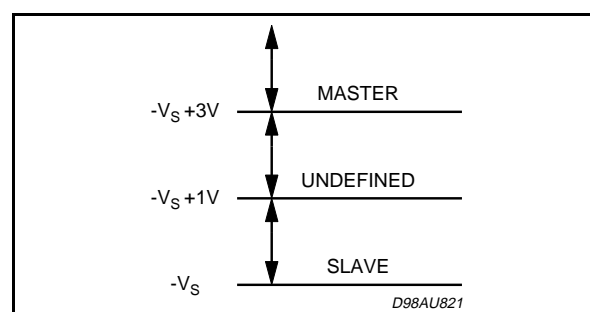
Slave function: pin 4 (Ref to pin 8 -V_S)**Note:**

If in the application, the speakers are connected via long wires, it is a good rule to add between the output and GND, a Boucherot Cell, in order to avoid dangerous spurious oscillations when the speakers terminal are shorted.

The suggested Boucherot Resistor is 3.9 Ω /2W and the capacitor is 1 μ F.

INTRODUCTION

In consumer electronics, an increasing demand has arisen for very high power monolithic audio amplifiers able to match, with a low cost, the performance obtained from the best discrete designs.

The task of realizing this linear integrated circuit in conventional bipolar technology is made extremely difficult by the occurrence of 2nd breakdown phenomenon. It limits the safe operating area (SOA) of the power devices, and, as a consequence, the maximum attainable output power, especially in presence of highly reactive loads.

Moreover, full exploitation of the SOA translates into a substantial increase in circuit and layout complexity due to the need of sophisticated protection circuits.

To overcome these substantial drawbacks, the use of power MOS devices, which are immune from secondary breakdown is highly desirable.

The device described has therefore been developed in a mixed bipolar-MOS high voltage technology called BCDII 100/120.

1) Output Stage

The main design task in developing a power operational amplifier, independently of the technology used, is that of realization of the output stage.

The solution shown as a principle schematic by Fig3 represents the DMOS unity - gain output buffer of the TDA7293.

This large-signal, high-power buffer must be capable of handling extremely high current and voltage levels while maintaining acceptably low harmonic distortion and good behaviour over

frequency response; moreover, an accurate control of quiescent current is required.

A local linearizing feedback, provided by differential amplifier A, is used to fulfil the above requirements, allowing a simple and effective quiescent current setting.

Proper biasing of the power output transistors alone is however not enough to guarantee the absence of crossover distortion.

While a linearization of the DC transfer characteristic of the stage is obtained, the dynamic behaviour of the system must be taken into account.

A significant aid in keeping the distortion contributed by the final stage as low as possible is provided by the compensation scheme, which exploits the direct connection of the Miller capacitor at the amplifier's output to introduce a local AC feedback path enclosing the output stage itself.

2) Protections

In designing a power IC, particular attention must be reserved to the circuits devoted to protection of the device from short circuit or overload conditions.

Due to the absence of the 2nd breakdown phenomenon, the SOA of the power DMOS transistors is delimited only by a maximum dissipation curve dependent on the duration of the applied stimulus.

In order to fully exploit the capabilities of the power transistors, the protection scheme implemented in this device combines a conventional SOA protection circuit with a novel local temperature sensing technique which "dynamically" controls the maximum dissipation.

Figure 3: Principle Schematic of a DMOS unity-gain buffer.

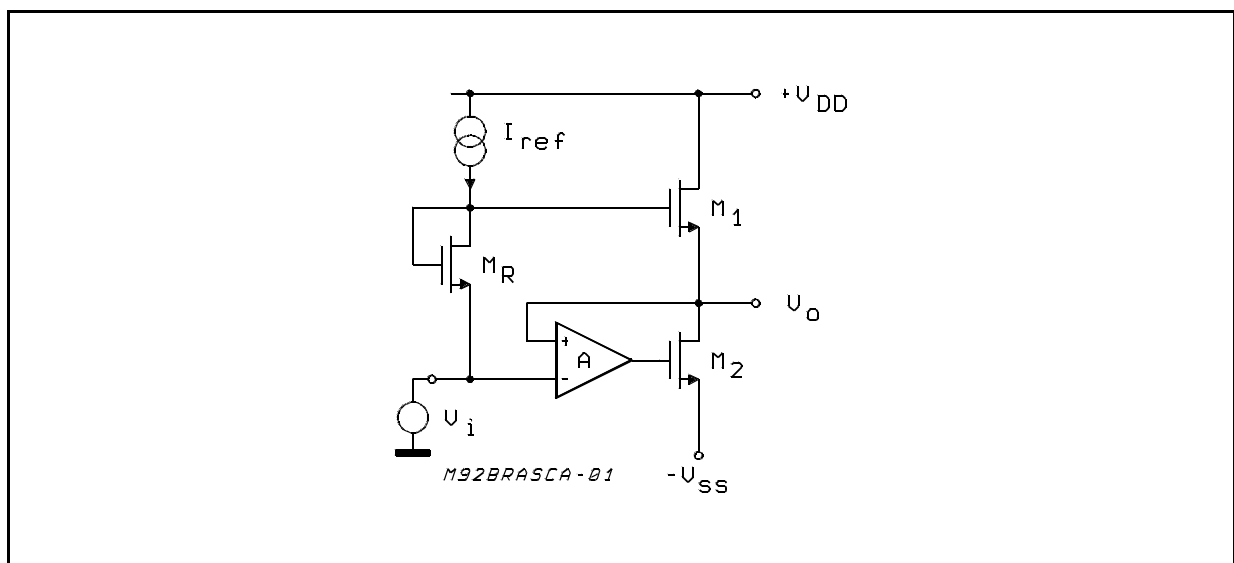
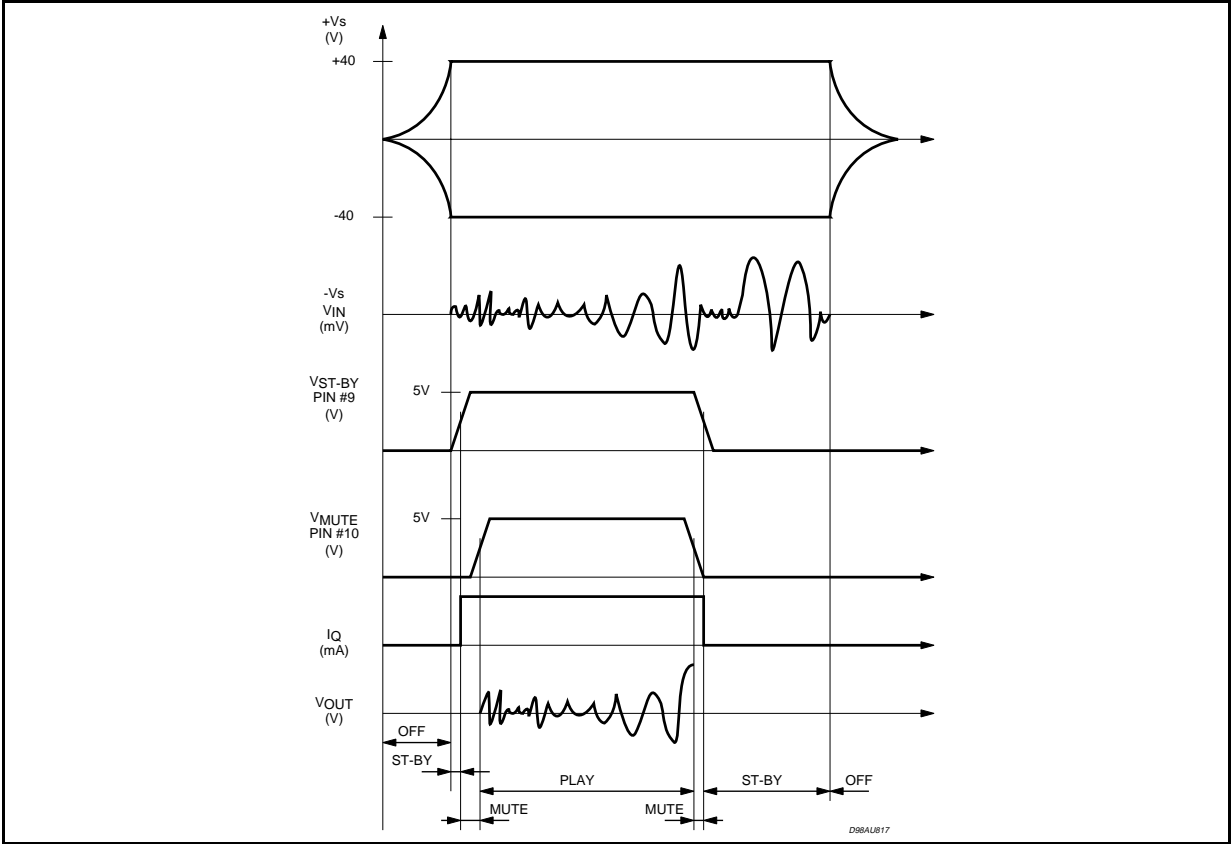

Figure 4: Turn ON/OFF Suggested Sequence



In addition to the overload protection described above, the device features a thermal shutdown circuit which initially puts the device into a muting state (@ $T_j = 150\text{ }^\circ\text{C}$) and then into stand-by (@ $T_j = 160\text{ }^\circ\text{C}$).

Full protection against electrostatic discharges on every pin is included.

Figure 5: Single Signal ST-BY/MUTE Control Circuit

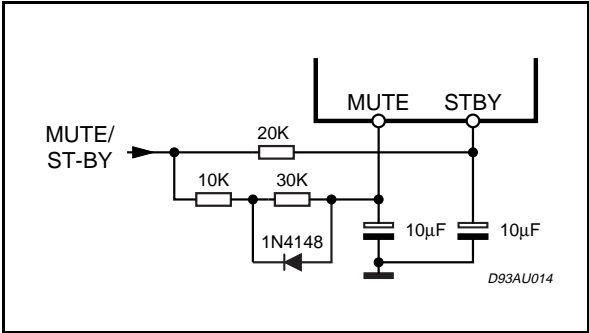

3) Other Features

The device is provided with both stand-by and

mute functions, independently driven by two CMOS logic compatible input pins.

The circuits dedicated to the switching on and off of the amplifier have been carefully optimized to avoid any kind of uncontrolled audible transient at the output.

The sequence that we recommend during the ON/OFF transients is shown by Figure 4.

The application of figure 5 shows the possibility of using only one command for both st-by and mute functions. On both the pins, the maximum applicable range corresponds to the operating supply voltage.

APPLICATION INFORMATION

HIGH-EFFICIENCY

Constraints of implementing high power solutions are the power dissipation and the size of the power supply. These are both due to the low efficiency of conventional AB class amplifier approaches.

Here below (figure 6) is described a circuit proposal for a high efficiency amplifier which can be adopted for both HI-FI and CAR-RADIO applications.



The TDA7293 is a monolithic MOS power amplifier which can be operated at 100V supply voltage (120V with no signal applied) while delivering output currents up to ± 6.5 A.

This allows the use of this device as a very high power amplifier (up to 180W as peak power with T.H.D.=10 % and $R_L = 4$ Ohm); the only drawback is the power dissipation, hardly manageable in the above power range.

The typical junction-to-case thermal resistance of the TDA7293 is 1 °C/W (max= 1.5 °C/W). To avoid that, in worst case conditions, the chip temperature exceeds 150 °C, the thermal resistance of the heatsink must be 0.038 °C/W (@ max ambient temperature of 50 °C).

As the above value is practically unreachable; a high efficiency system is needed in those cases where the continuous RMS output power is higher than 50-60 W.

The TDA7293 was designed to work also in higher efficiency way.

For this reason there are four power supply pins: two intended for the signal part and two for the power part.

T1 and T2 are two power transistors that only operate when the output power reaches a certain threshold (e.g. 20 W). If the output power increases, these transistors are switched on during the portion of the signal where more output voltage swing is needed, thus "bootstrapping" the power supply pins (#13 and #15).

The current generators formed by T4, T7, zener diodes Z1, Z2 and resistors R7, R8 define the minimum drop across the power MOS transistors of the TDA7293. L1, L2, L3 and the snubbers C9, R1 and C10, R2 stabilize the loops formed by the "bootstrap" circuits and the output stage of the TDA7293.

By considering again a maximum average output power (music signal) of 20W, in case of the high efficiency application, the thermal resistance value needed from the heatsink is 2.2 °C/W ($V_s = \pm 50$ V and $R_L = 8$ Ohm).

All components (TDA7293 and power transistors T1 and T2) can be placed on a 1.5 °C/W heatsink, with the power darlington electrically insulated from the heatsink.

Since the total power dissipation is less than that of a usual class AB amplifier, additional cost savings can be obtained while optimizing the power supply, even with a high heatsink .

BRIDGE APPLICATION

Another application suggestion is the BRIDGE configuration, where two TDA7293 are used.

In this application, the value of the load must not be lower than 8 Ohm for dissipation and current capability reasons.

A suitable field of application includes HI-FI/TV subwoofers realizations.

The main advantages offered by this solution are:

- High power performances with limited supply voltage level.
- Considerably high output power even with high load values (i.e. 16 Ohm).

With $R_L = 8$ Ohm, $V_s = \pm 25$ V the maximum output power obtainable is 150 W, while with $R_L = 16$ Ohm, $V_s = \pm 40$ V the maximum Pout is 200 W.

APPLICATION NOTE: (ref. fig. 7)

Modular Application (more Devices in Parallel)

The use of the modular application lets very high power be delivered to very low impedance loads. The modular application implies one device to act as a master and the others as slaves.

The slave power stages are driven by the master device and work in parallel all together, while the input and the gain stages of the slave device are disabled, the figure below shows the connections required to configure two devices to work together.

- The master chip connections are the same as the normal single ones.
- The outputs can be connected together **without the need of any ballast resistance**.
- The slave SGND pin must be tied to the negative supply.
- The slave ST-BY and MUTE pins must be connected to the master ST-BY and MUTE pins.
- The bootstrap lines must be connected together and the bootstrap capacitor must be increased: for N devices the bootstrap capacitor must be $22\mu\text{F}$ times N.
- The slave IN-pin must be connected to the negative supply.

THE BOOTSTRAP CAPACITOR

For compatibility purpose with the previous devices of the family, the bootstrap capacitor can be connected both between the bootstrap pin (6) and the output pin (14) or between the bootstrap pin (6) and the bootstrap loader pin (12).

When the bootcap is connected between pin 6 and 14, the maximum supply voltage in presence of output signal is limited to 100V, due the bootstrap capacitor overvoltage.

When the bootcap is connected between pins 6 and 12 the maximum supply voltage extend to the full voltage that the technology can stand: 120V.

This is accomplished by the clamp introduced at the bootstrap loader pin (12): this pin follows the output voltage up to 100V and remains clamped at 100V for higher output voltages. This feature lets the output voltage swing up to a gate-source voltage from the positive supply ($V_s - 3$ to 6V).

Figure 6: High Efficiency Application Circuit

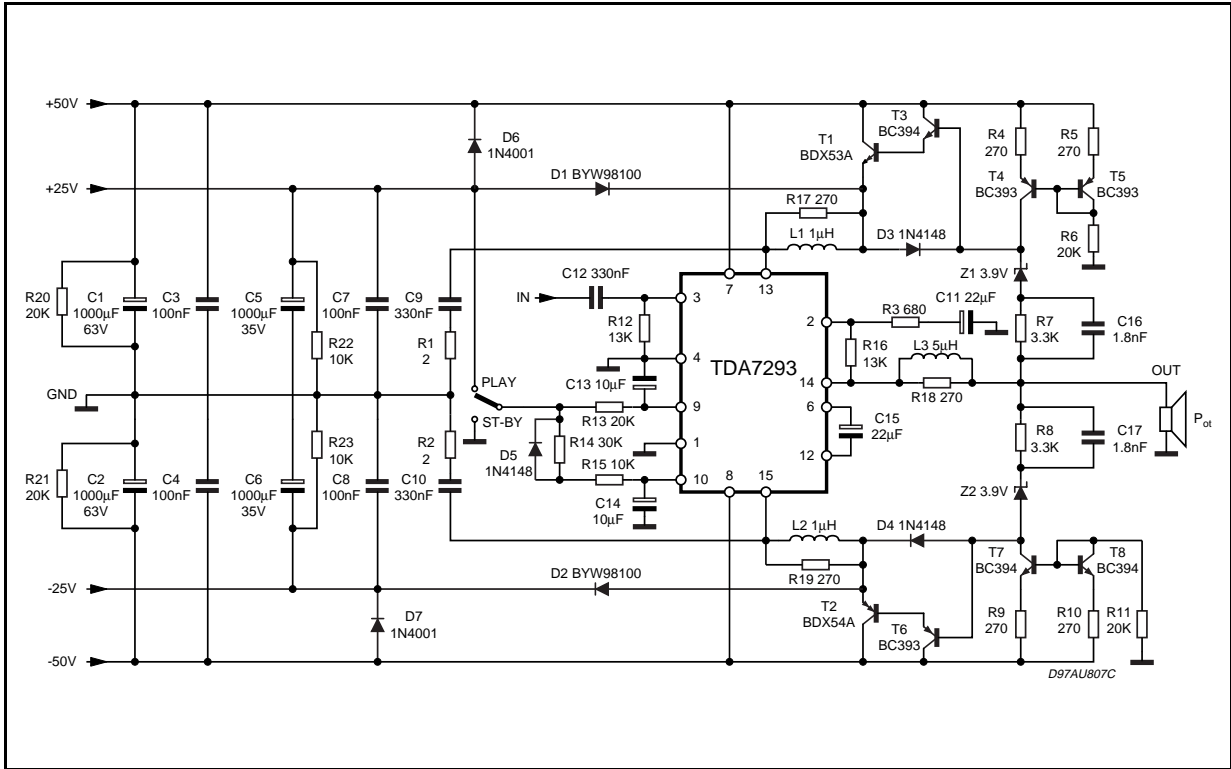

Figure 6a: PCB and Component Layout of the fig. 6

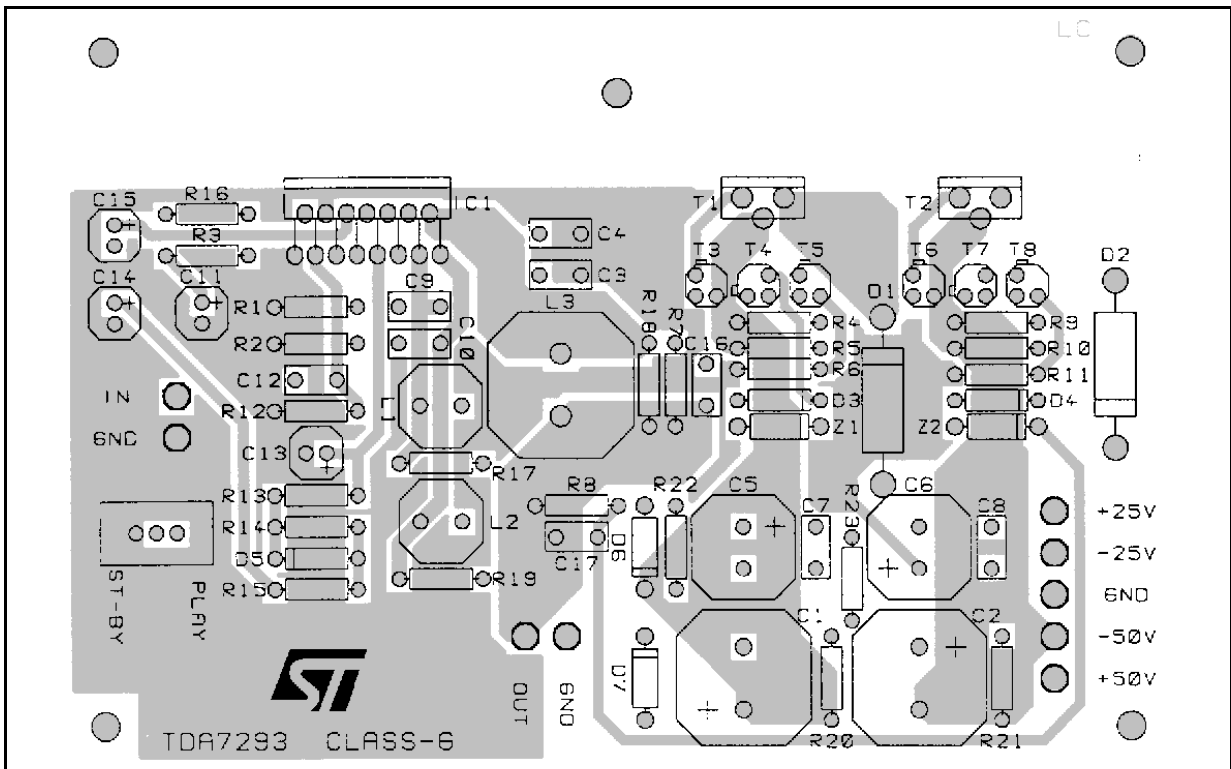

Figure 6b: PCB - Solder Side of the fig. 6.

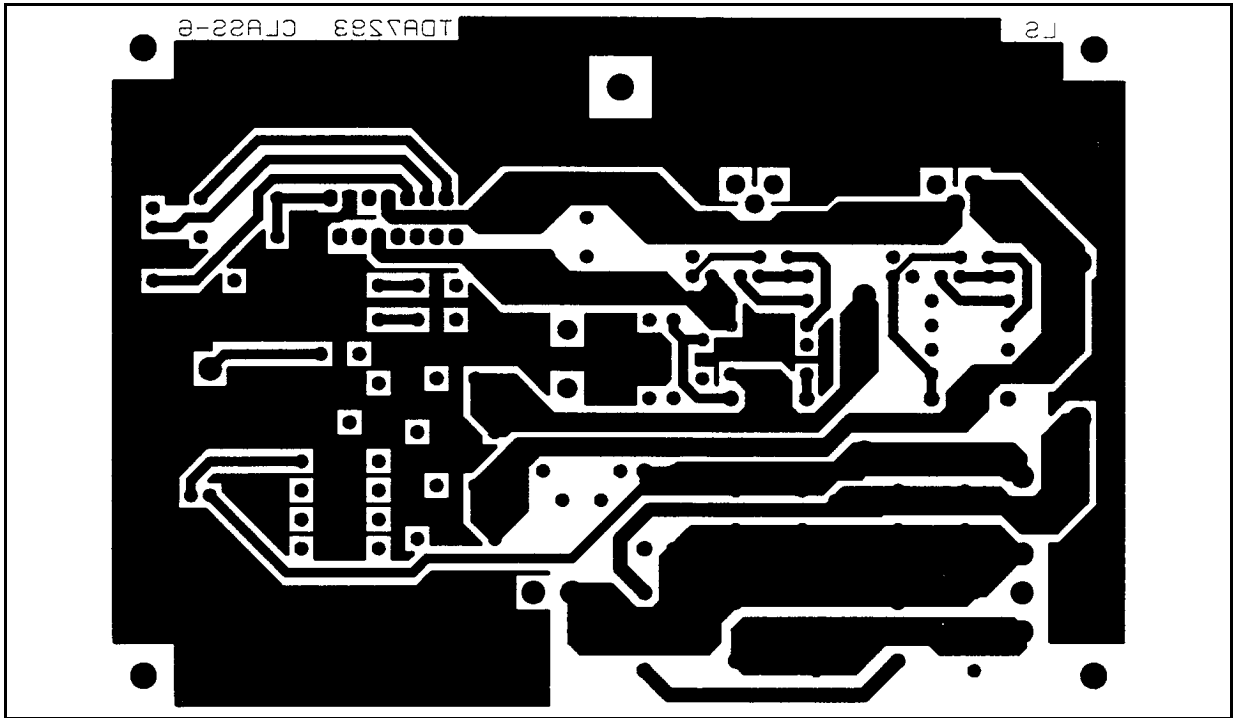

Figure 7: Modular Application Circuit

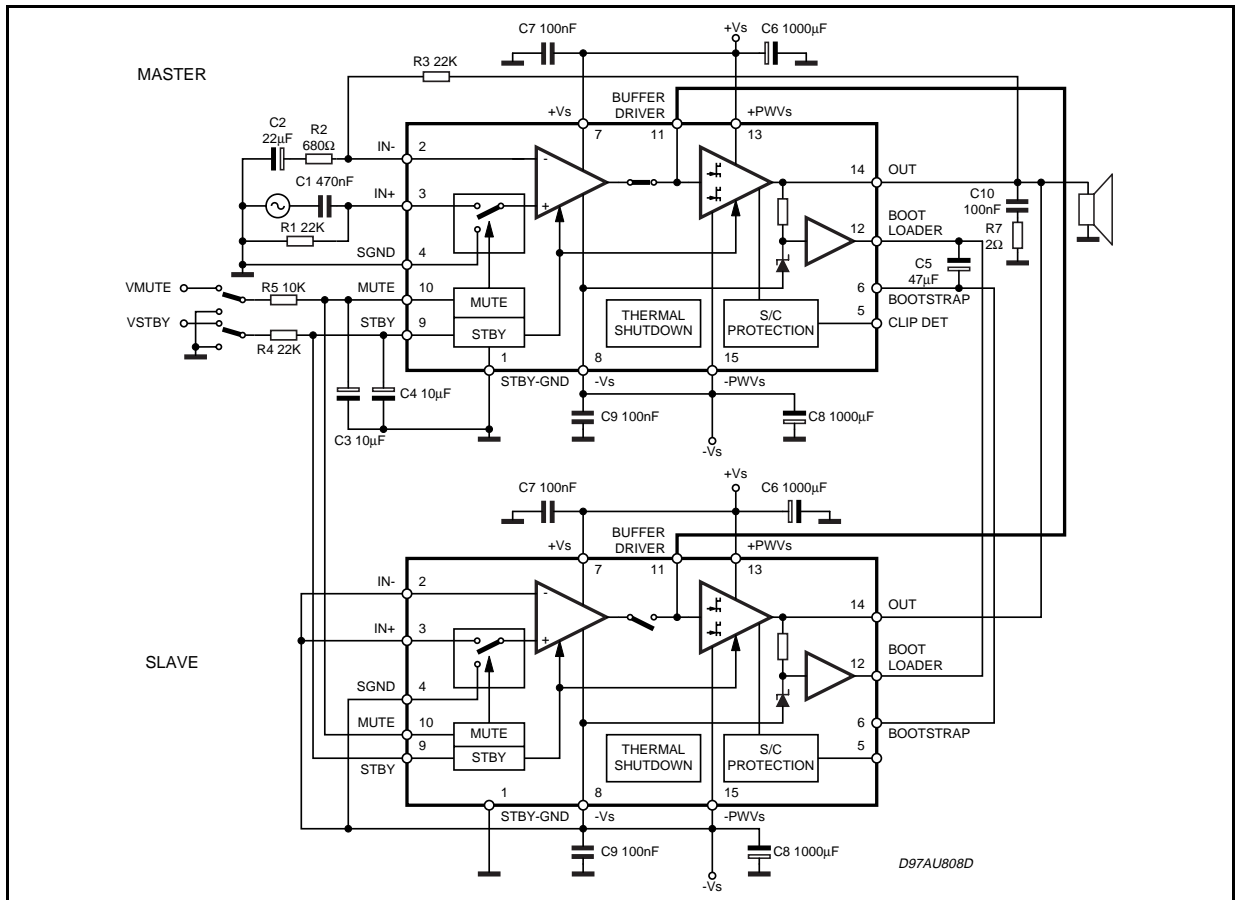

Figure 8a: Modular Application P.C. Board and Component Layout (scale 1:1) (Component SIDE)

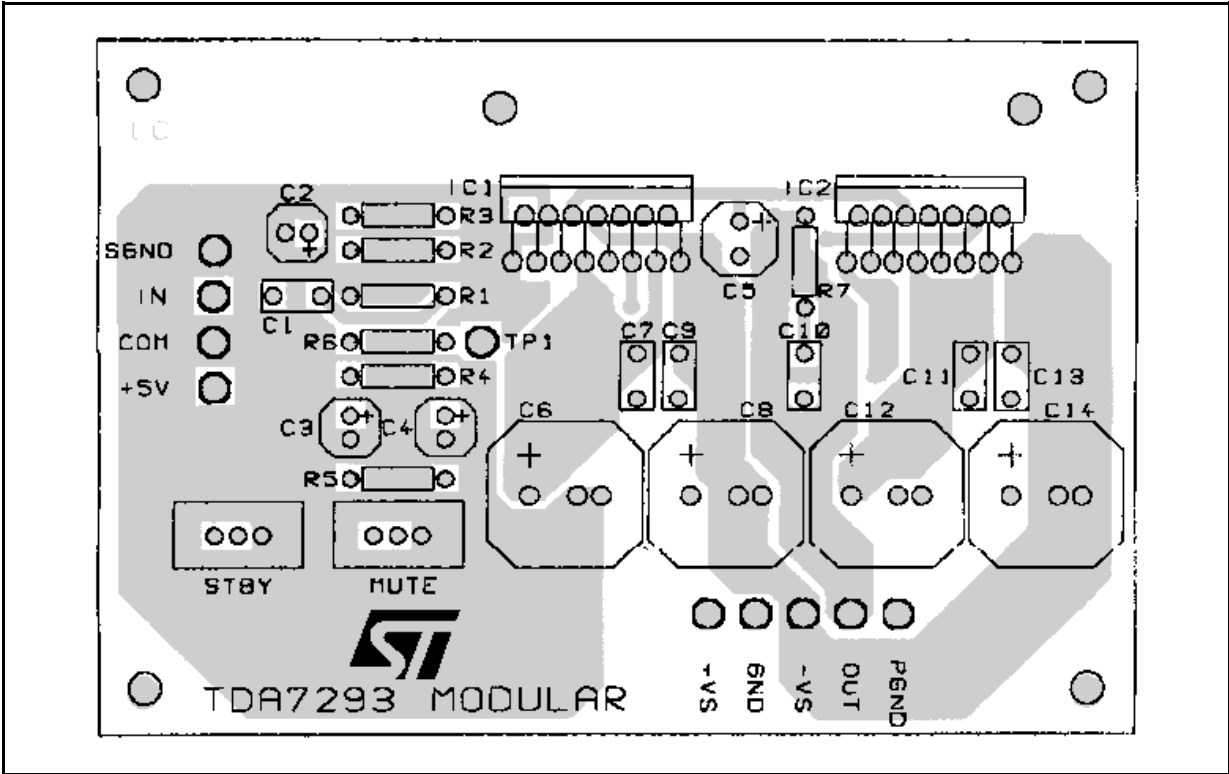

Figure 8b: Modular Application P.C. Board and Component Layout (scale 1:1) (Solder SIDE)

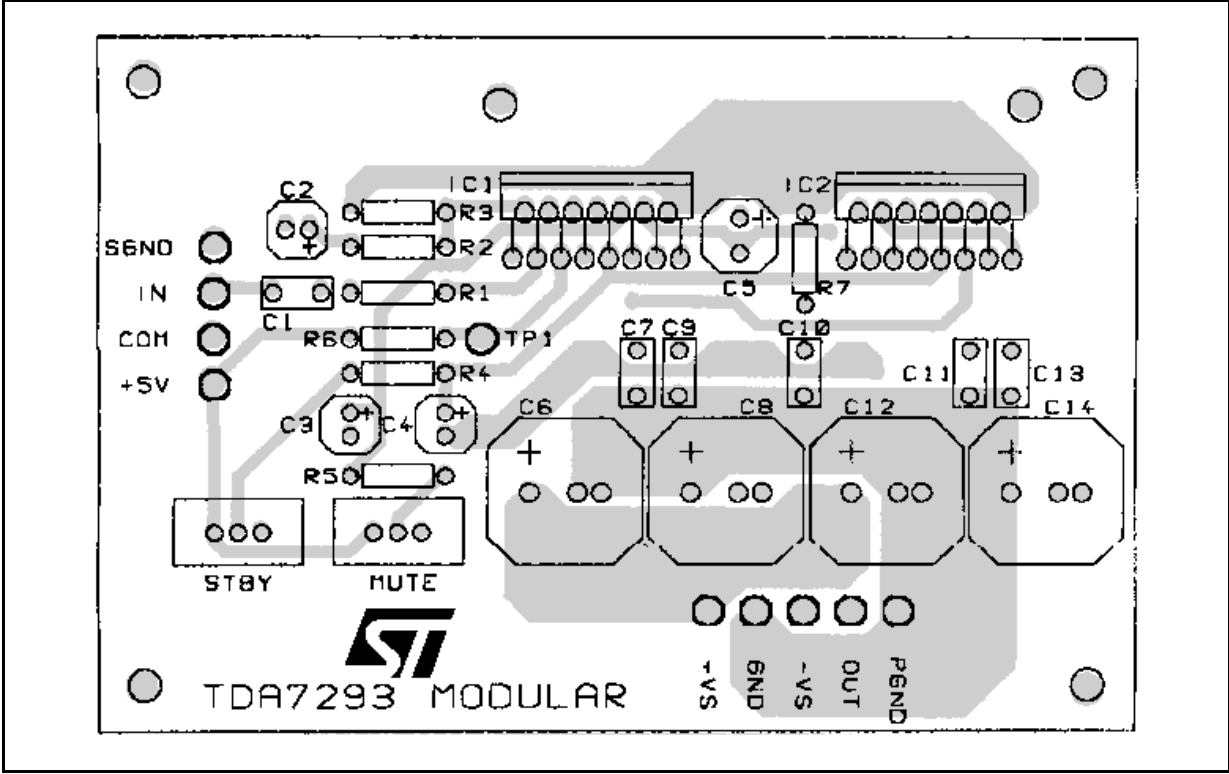

Figure 9: Distortion vs Output Power

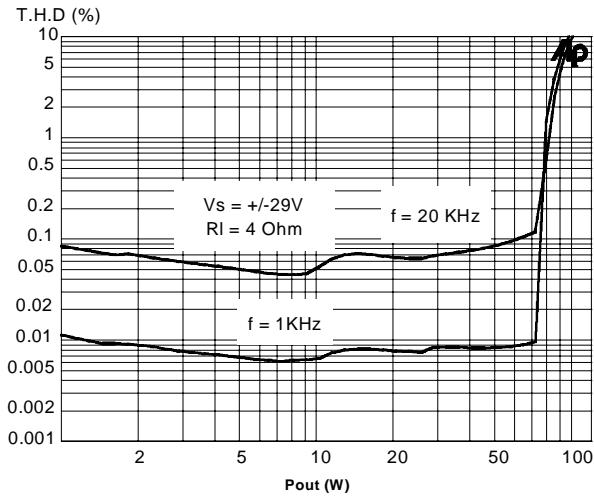

Figure 10: Distortion vs Output Power

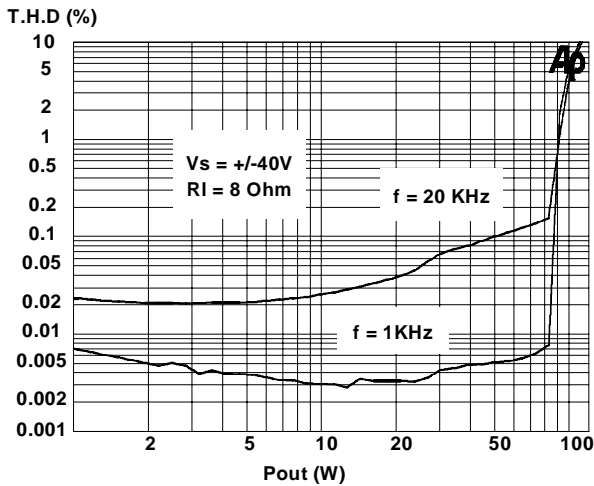

Figure 11: Distortion vs Frequency

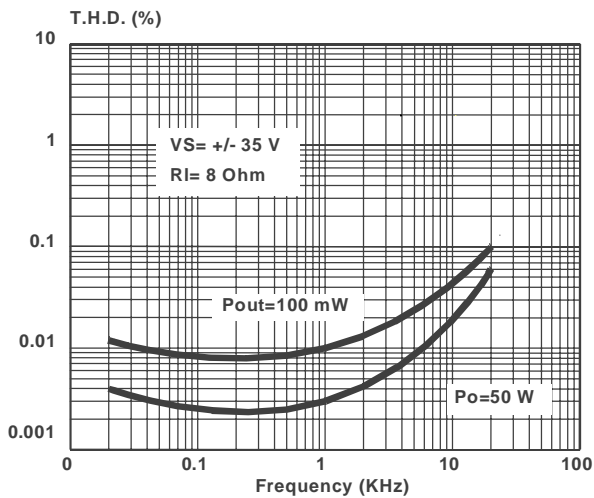

Figure 12: Modular Application Derating Rload vs Vsupply (ref. fig. 7)

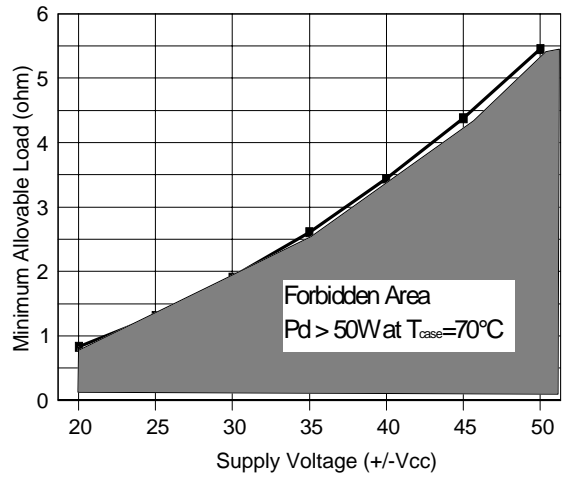

Figure 13: Modular Application Pd vs Vsupply (ref. fig. 7)

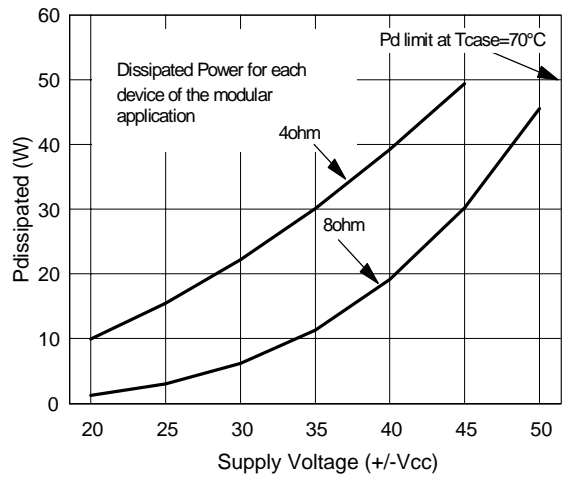
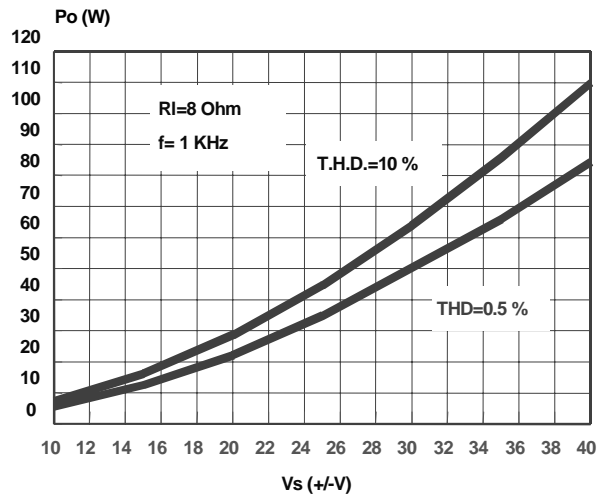
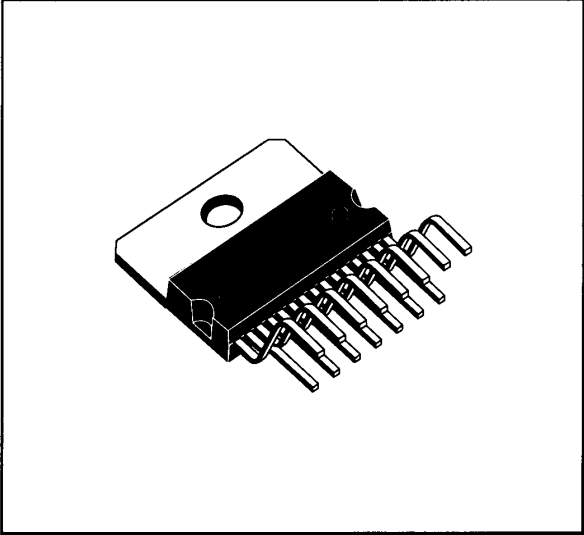

Figure 14: Output Power vs. Supply Voltage



DIM.	mm			inch		
	MIN.	TYP.	MAX.	MIN.	TYP.	MAX.
A			5			0.197
B			2.65			0.104
C			1.6			0.063
D		1			0.039	
E	0.49		0.55	0.019		0.022
F	0.66		0.75	0.026		0.030
G	1.02	1.27	1.52	0.040	0.050	0.060
G1	17.53	17.78	18.03	0.690	0.700	0.710
H1	19.6			0.772		
H2			20.2			0.795
L	21.9	22.2	22.5	0.862	0.874	0.886
L1	21.7	22.1	22.5	0.854	0.870	0.886
L2	17.65		18.1	0.695		0.713
L3	17.25	17.5	17.75	0.679	0.689	0.699
L4	10.3	10.7	10.9	0.406	0.421	0.429
L7	2.65		2.9	0.104		0.114
M	4.25	4.55	4.85	0.167	0.179	0.191
M1	4.63	5.08	5.53	0.182	0.200	0.218
S	1.9		2.6	0.075		0.102
S1	1.9		2.6	0.075		0.102
Dia1	3.65		3.85	0.144		0.152

OUTLINE AND MECHANICAL DATA



Multiwatt15 V

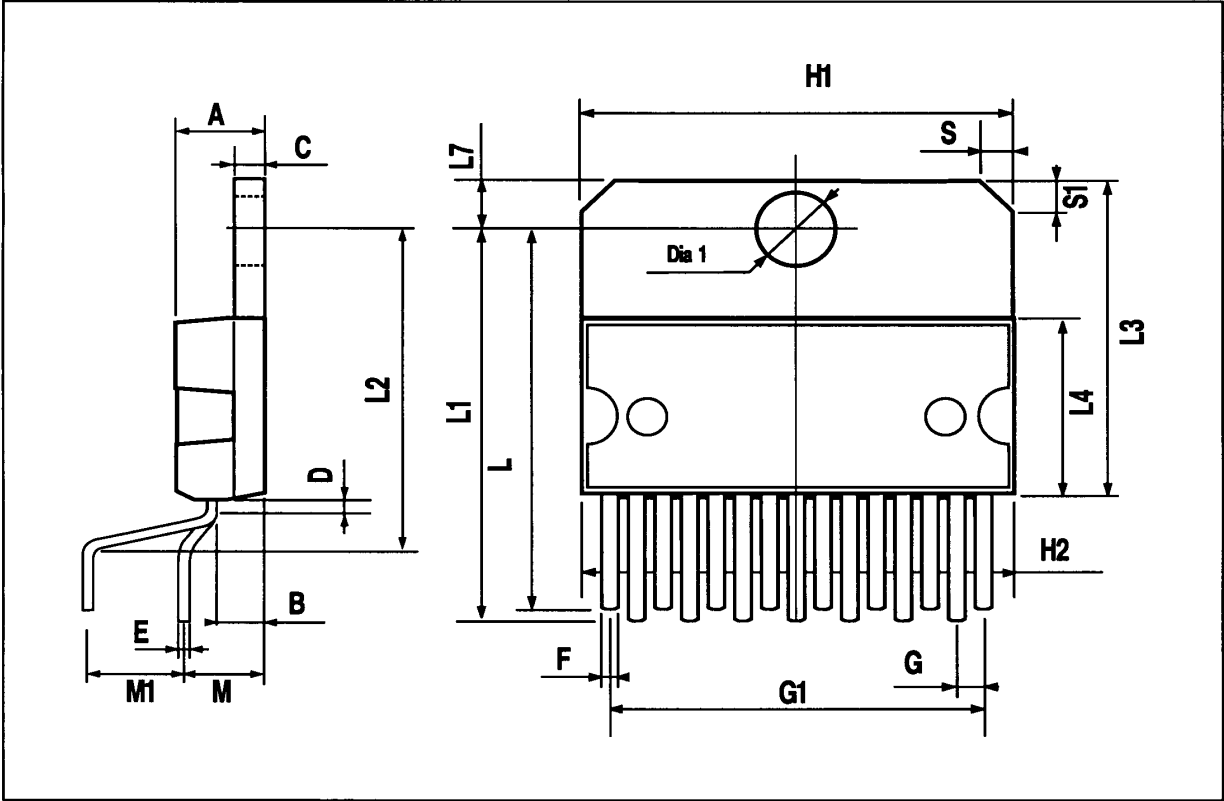

DIM.	mm			inch		
	MIN.	TYP.	MAX.	MIN.	TYP.	MAX.
A			5			0.197
B			2.65			0.104
C			1.6			0.063
E	0.49		0.55	0.019		0.022
F	0.66		0.75	0.026		0.030
G	1.14	1.27	1.4	0.045	0.050	0.055
G1	17.57	17.78	17.91	0.692	0.700	0.705
H1	19.6			0.772		
H2			20.2			0.795
L		20.57			0.810	
L1		18.03			0.710	
L2		2.54			0.100	
L3	17.25	17.5	17.75	0.679	0.689	0.699
L4	10.3	10.7	10.9	0.406	0.421	0.429
L5		5.28			0.208	
L6		2.38			0.094	
L7	2.65		2.9	0.104		0.114
S	1.9		2.6	0.075		0.102
S1	1.9		2.6	0.075		0.102
Dia1	3.65		3.85	0.144		0.152

OUTLINE AND MECHANICAL DATA

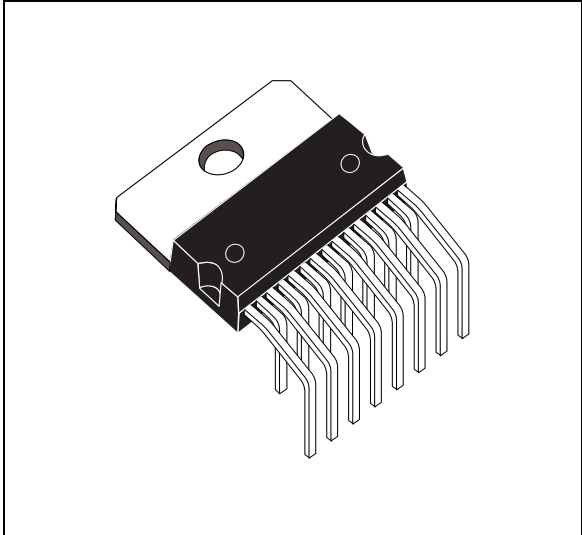

Multiwatt15 H

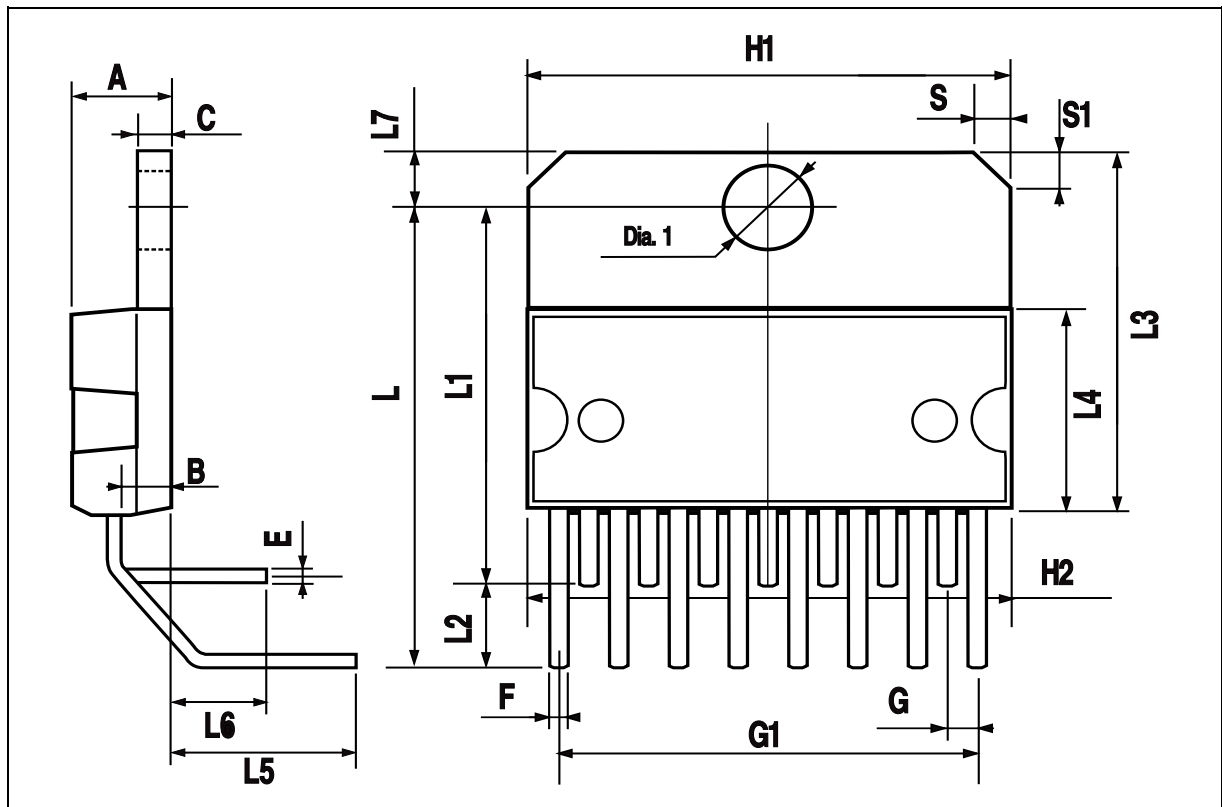

Information furnished is believed to be accurate and reliable. However, STMicroelectronics assumes no responsibility for the consequences of use of such information nor for any infringement of patents or other rights of third parties which may result from its use. No license is granted by implication or otherwise under any patent or patent rights of STMicroelectronics. Specification mentioned in this publication are subject to change without notice. This publication supersedes and replaces all information previously supplied. STMicroelectronics products are not authorized for use as critical components in life support devices or systems without express written approval of STMicroelectronics.

The ST logo is a registered trademark of STMicroelectronics

© 2003 STMicroelectronics – Printed in Italy – All Rights Reserved

STMicroelectronics GROUP OF COMPANIES

Australia - Brazil - Canada - China - Finland - France - Germany - Hong Kong - India - Israel - Italy - Japan - Malaysia - Malta - Morocco -
Singapore - Spain - Sweden - Switzerland - United Kingdom - United States.

<http://www.st.com>

